

Connection Detail

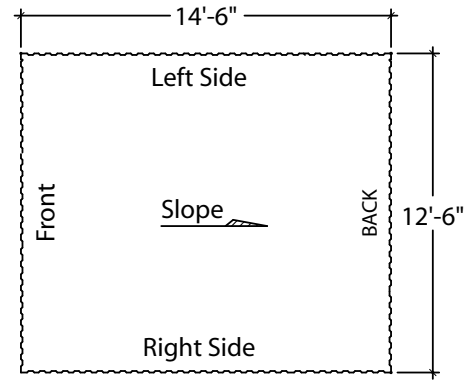

Roof Plan

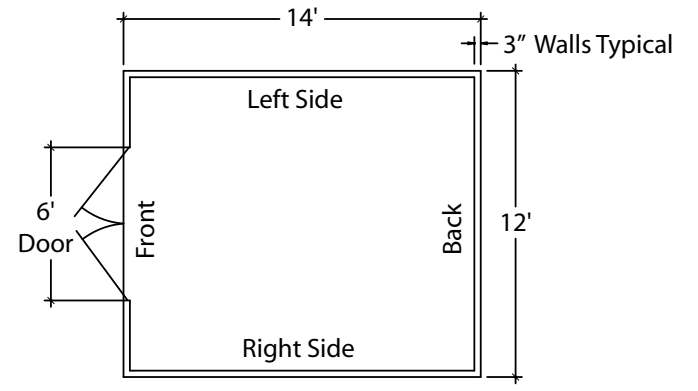

Floor Plan

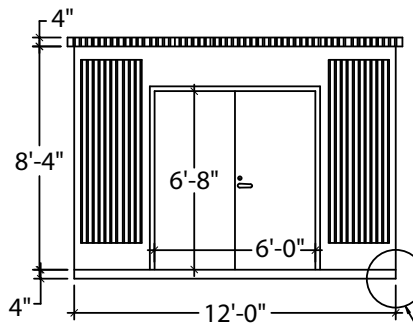

Front

See Connection Detail

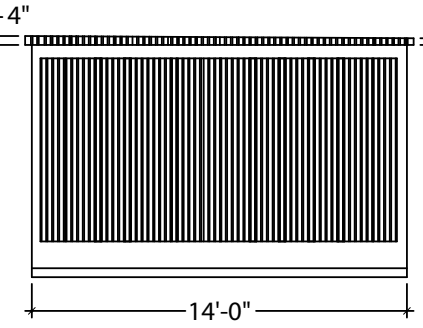

Right Side

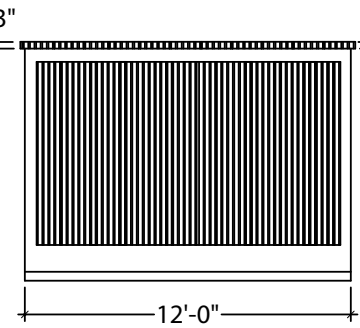

Back

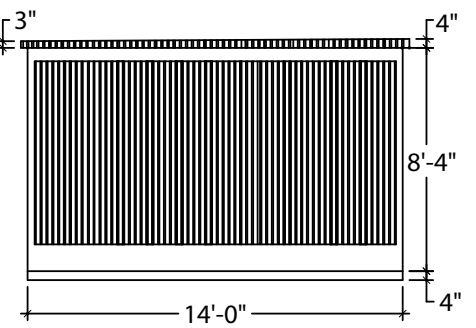

Left Side

Exterior Color

- Concrete
- Other: _____

Door Color

- Yorktown Brown
- Other: _____

Exterior Finish

- Sandblasted Ribbed
- Exposed Aggregate Ribbed

- 1) All required openings for electric, mechanical, louvers, etc. must be sized and located by buyer on this drawing (Opening sizes and locations may have to be altered if they interfere with connections or reinforcing)
- 2) All views are from exterior
- 3) A signed copy must be returned before building can be released for production

SMITH-MIDLAND EXCELLENCE IN PRECAST CONCRETE		
PO Box 300 • Midland, VA 22728 • (540) 439-3266 • f:(540) 439-1232 • smithmidland.com		
CUSTOMER: _____		
JOB LOCATION: _____		
PRODUCT: 12' x 14' EASI-CAST	DR BY: CHK:	DATE: DATE:
SHEET NO. _____	MAKE _____	JOB NO. _____
OF _____		